



N35.125
GRAFTER 
GREEN

Chassis Cab

ISUZU
TRUCK 

specifications:

Isuzu 'Grafter Green' N35.125(TE) Light 3.5T GVW / EURO 6 4x2 rigid twin rear wheels

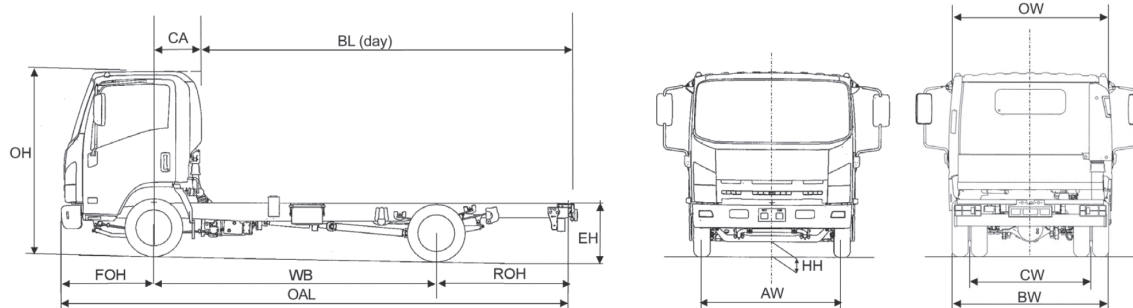

Axle weights (kg)			
UK maximum Vehicle Weights (kg)	GVW	3500	3500
	GTW*	7000	7000
UK Axle design weights (kg)	Front	2100	2100
	Rear	2435	2435

Weights (kg)			
Cab type		day	day
Wheelbase	WB	2500	3360
Vehicle Mass Unladen	Front	1380	1400
	Rear	560	624
Total		1940	2024
GVW		3500	3500
Body & Payload Allowance		1560	1476
Max. Permissible Trailer Weight*		3500	3500

Dimensions (mm)			
Overall Length	OAL	4780	6015
Overhang - Front	FOH	1100	1100
Overhang - Rear	ROH	1135	1555
Cab Gap	CB	130	130
C/L Front Axle to Rear of Cab	CA	463	463
Recommended Body Length	BL	3200	4267
Chassis Frame Width		700	700
Recommended Body Width		1945	1945
Recommended Maximum Body Width		2275**	2275**
Cab Width	OW	1770	1770
Overall Height (Unladen)	OH	2150	2160
Chassis Height (Unladen)	EH	725	725
Minimum Road Clearance	HH	180	180
Track - Front	AW	1395	1395
Track - Rear	CW	1425	1425
Rear Axle Width	BW	1860	1860

*Tachograph regulations may apply

**Wide mirror arms apply at extra cost

1. Unladen weights excludes driver and fuel. Includes spare wheel + carrier (Tolerance +/- 3%). Spare wheel and carrier 38kg.
2. Body lengths are given as a guide only. Bodybuilders are responsible for ensuring all legal requirements are met. 3. Maximum body lengths are calculated to remain within the overhang ratio of 60% of the wheel base. Cab gaps may vary. 4. Isuzu Truck (UK) Ltd. shall have no liability whatsoever should the information supplied have incorrect data, descriptions or illustrations.

N35.125(TE) Light Mechanical Specification (standard equipment)



EURO 6

POWER & TORQUE

Engine	
Make & model:	RZ4E – Isuzu turbo intercooled DOHC 4 cylinder diesel. Lean NOx trap.
Bore x stroke:	80 x 94.4mm
Capacity:	Max Power:
	at 3200rpm

Transmission	
Make & model:	Isuzu electro hydraulic controlled 6 speed synchromesh MYY6E with fully automated and sequential shift modes.
Ratios:	1st - 5.979; 2nd - 3.434; 3rd - 2.040; 4th - 1.379; 5th - 1.000; 6th - 0.759; Reverse - 5.701
Rear Axle Ratio:	4.300:1
Clutch	
Type:	Fluid coupling torque convertor type with lock up clutch.

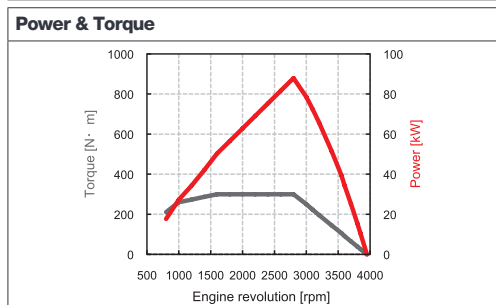

Electrical	
Type:	2 x 12V, 540CCA 70Ah battery with 12V/150A alternator.

Tyres/Wheels	
Tyres:	205/75 R16 radial.
Wheels:	5.50J x 16, 5-stud.
Spare:	1 x wheel and tyre.

Revised Light Frame	
Type:	Parallel ladder type channel section straight side rails, upper flange.

Axles	
Front:	Independent type.
Rear:	Banjo fully floating.

Suspension	
Front:	Double wishbone and transverse parallel leaf suspension with hydraulic shock absorbers.
Rear:	Semi-elliptical steel suspension with hydraulic shock absorbers.

Brakes	
System:	Vacuum servo assisted hydraulic dual line with ABS, EBD (electronic brake distribution), EVSC (electronic vehicle stability control), ASR (anti slip regulation).
Front:	293mm ventilated discs with asbestos free pads.
Rear:	275mm ventilated discs with asbestos free pads.
Park:	Mechanical drum brake rear of transmission.

Fuel Tank	
Capacity:	

CAB FEATURES

Cab Exterior	
Type:	Hexapod, white (standard) or metallic grey (option), all-steel.
Features:	Manual tilt to 45 deg. Tinted windscreen. Chrome radiator grille. Plastic resin non-slip entry steps. 90 deg. opening doors. Zinc galvanised frame structure, Steel reinforced composite front bumper with fog and daytime running lamps. Two halogen head lamps with indicators. Front mudguards with spray suppression. Keyless door entry and immobiliser.

Cab Interior	
Features:	Flame-resistant interior trim. Vinyl floor matting. Pillar mounted entrance grab handles both sides. Driver and passenger SRS airbags.

Seats (cloth)	
Features:	Driver's fully adjustable suspension seat with head restraint. Dual passenger seat with folding back. Driver and outer passenger retractable diagonal seat belts with pre-tensioner. Centre seat lap belt.

Vision	
Features:	Large foldable mirrors. Interior rear view mirror on collapsible mounting. Driver and passenger sun visors. Deep cut side windows to reduce blind spots. Electric windows with driver control and lock.

Steering	
Features:	Rack and pinion with full integral hydraulic power assistance. Tilt and telescopic steering column.

Instruments	
Features:	Speedometer with odometer & trip. Rev counter. Fuel gauge. Engine coolant temperature.

Switches & Electrical	
Features:	Combination stalk incorporating headlamps, indicators, fog lamp, washers and wipers. Steering wheel horn. Engine idle control. Headlamp levelling. Engine quick warm-up. Central locking. Cigarette lighter. DPD, EVSC and ASR control. Hazard warning lights. Kenwood DAB radio with Bluetooth (Sat Nav option available). Gear selector. First gear start. Economy mode.

Warning/Indicator Lamps	
Features:	Battery charge. Oil pressure. Low fuel. Glow plug operation. High beam and indicators. Park brake warning. Fuel/water separator. Check engine. Engine over heat. EVSC. ABS. Front and rear fog lights. Seat belt warning. Brake fluid level. SRS air bag. Brake vacuum loss. DPD operation. Gear position indicator.

Tool Kit	
Features:	Jack with a small selection of hand tools.

WARRANTY

All chassis cabs come with a 3 year unlimited mileage warranty and roadside assistance as standard. Terms and conditions apply.

Isuzu-backed Repair and Maintenance contracts available upon request.

SAFETY & SECURITY

R29 cab strength:	Complies with ECE-R29 cab strength standard.
Central locking:	Central locking with remote keyless entry and immobiliser.
Rear bumper:	Aluminium rear under run bar.
Seatbelts:	Red diagonal and lap belts.